

465 Channel with Q-Guard Galvanized Steel Rail Spec Sheet

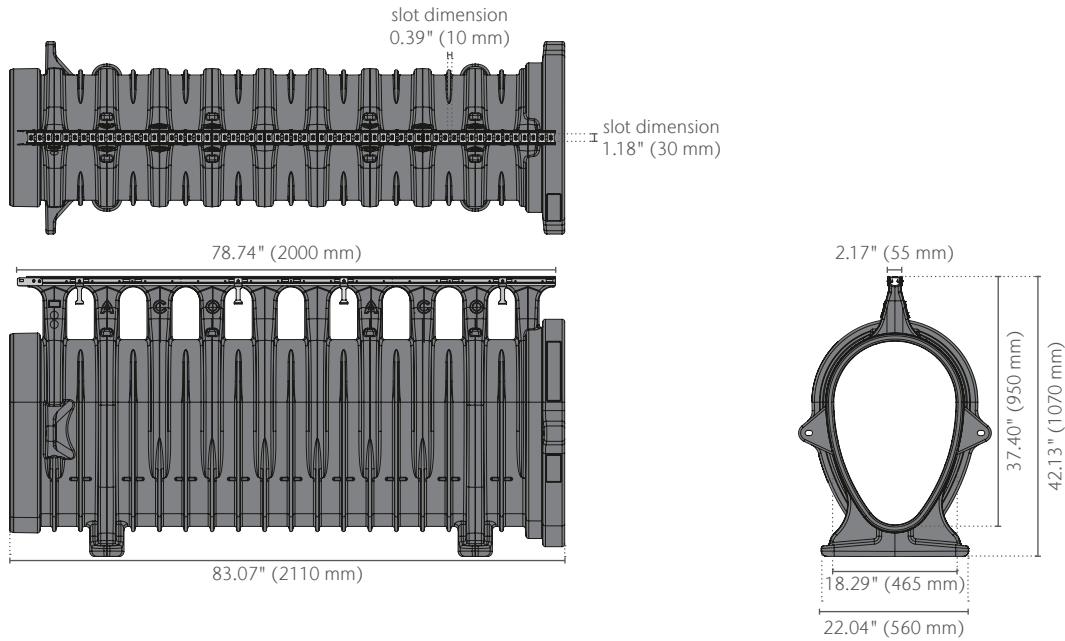

Two Meter Channel



Outlet Flume/Catch Basin Connectors

Male

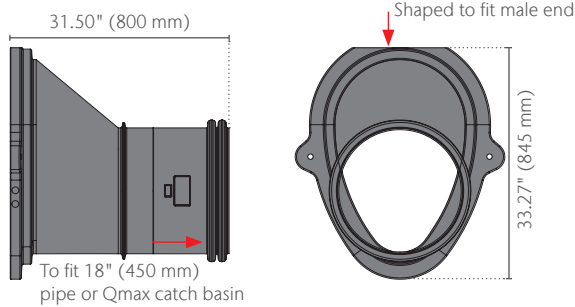

Female

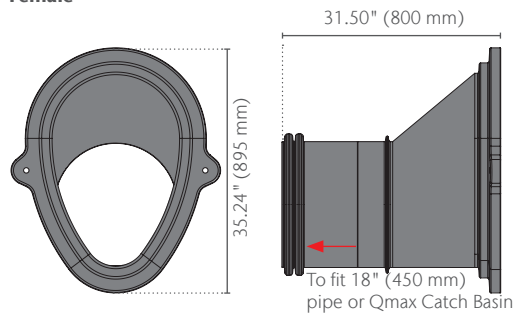

Closing End Plate

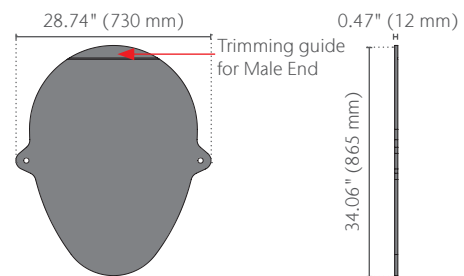

Closing End Cap

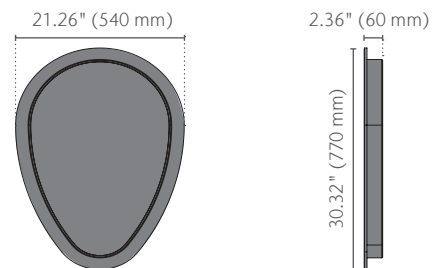

465 Channel with Q-Guard Galvanized Steel Rail Spec Sheet



Qmax 465 to 600 System Connection

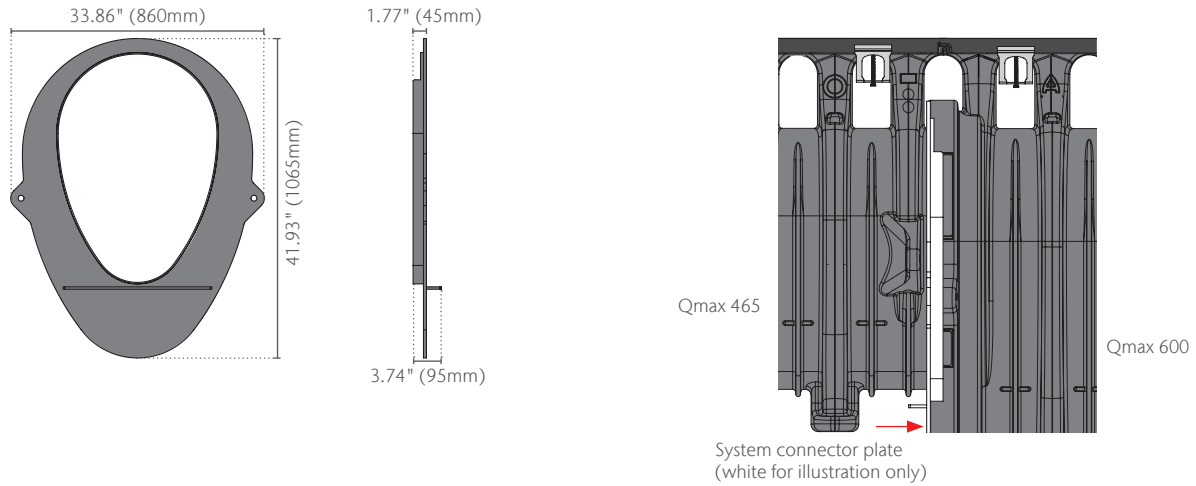

Typical Qmax 465 Connection to Catch Basin

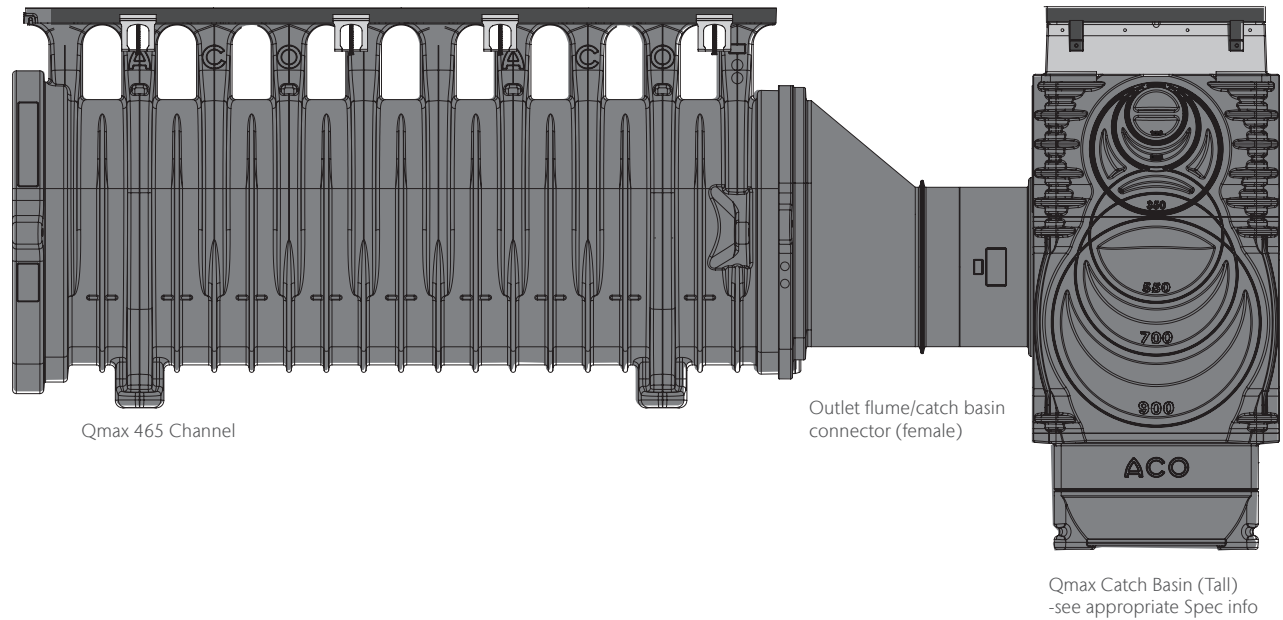

465 Channel with Q-Guard Galvanized Steel Rail Spec Sheet



Product Name	Part No.	Invert Depth in (mm)	Weight lbs
Qmax 465 Channel with Q-Guard Galvanized Steel Rail - 78.75" (2000 mm)	32833	37.40 (950)	86.7
Accessories			
Qmax 465 Closing end plate (Fits male/female end of uncut channels)	32835	-	10.8
Qmax 465 Closing end cap (Easy push fit cap for cut channel ends)	32887	-	6.8
Qmax 465 to Qmax 600 System connector plate	32883	-	8.1
Qmax 465 Outlet flume/catch basin connector (male)	44362	-	16.9
Qmax 465 Outlet flume/catch basin connector (female)	44363	-	17.2

Specification Summary

General

The surface drainage system shall be ACO Qmax 465 with Galvanized Steel Q-Guard top as manufactured by ACO, Inc. or equal approved.

Grates

Grates shall be factory fitted to MDPE bodies to provide a monolithic unit. Water intake area per 2 meter unit will be 25.90 in² (16,712 mm²)

Catch Basin

See appropriate spec info for catch basin information.

Installation

The trench drain system shall be installed in accordance with the manufacturer's installation instructions and recommendations.

Materials

The trench system bodies shall be manufactured from medium density polyethylene with:

- Compressive strength: 8,450 psi
- Flexural strength: 2,224 psi
- Water absorption 0.31%

The nominal clear opening shall be 18.29" (465 mm) with unit overall width of 22.04" (560 mm). Units shall be manufactured with a neutral invert of 37.40" (950 mm). Each unit will feature a full radius in the channel bottom and a male to female interconnecting end profile, a rubber seal shall be fitted to the bell end of the channel unit. Units shall have molded anchoring features on the outside wall to ensure maximum mechanical bond to the surrounding bedding material and pavement surface.



EN 1433 Load Class C
56,202 lbs — 1,160 psi

ACO, Inc.

© January 2026 ACO, Inc.

All reasonable care has been taken in compiling the information in this document. All recommendations and suggestions on the use of ACO products are made without guarantee since the conditions of use are beyond the control of the company. It is the customer's responsibility to ensure that each product is fit for its intended purpose and that the actual conditions of use are suitable. ACO, Inc. reserves the right to change products and specifications without notice.

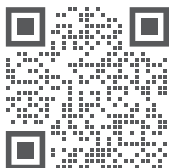

info@acousa.com
www.acousa.com

